



## Simple Motion Module

LD77MH4

**New** LD77MH16

Advanced motion control similar to a positioning module

Simple Motion Module, now part of MELSEC-L Series

4-axis type

**New** 16-axis type



# Simple Motion

**Making Motion Simple**

### Advanced and wide-range motion control

- Positioning control • Speed control • Torque control • Cam control
- Synchronous control • Mark detection function

### Graphical setting software

### Simple and smart system installation

# Advanced Motion Control

The MELSEC-L Series lineup now includes the Simple Motion Module in addition to the regular positioning modules. Various control functions previously only possible with Motion Controllers, such as synchronous control, are now available in the same manner as a positioning module.

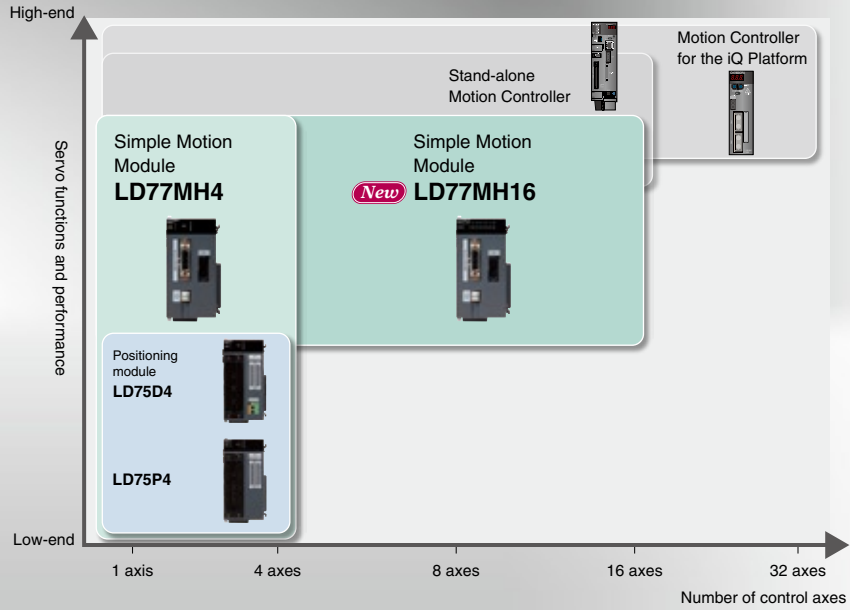

## Features

### Making Motion Simple in various applications

A variety of controls including positioning control, speed control, torque control, cam control and synchronous control can be realized easily just with simple parameter settings and a sequence program.

#### Positioning control

- Various applications are supported with extensive control formats including linear interpolation control (up to 4 axes), 2-axis circular interpolation control, fixed feed control and continuous orbit control.
- Execute automatic operation by setting the positioning addresses and speeds, etc., easily from a sequence program.
- Powerful auxiliary functions such as M codes, skip function, step operation and target position change function.

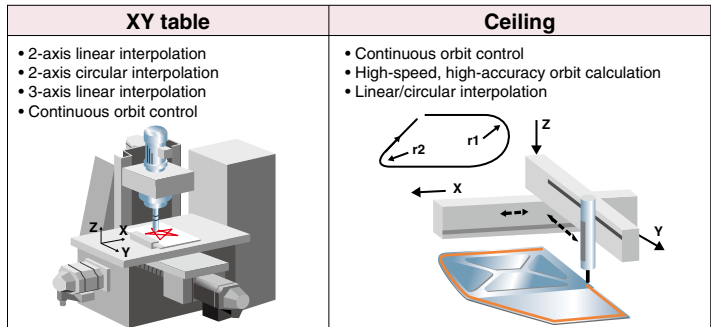

#### Speed and torque control are also available

- Tension control applications such as rewinding and winding axes are supported.
  - Control can be switched between “positioning control”, “speed and torque control” and “position control”.
- As a result, it is now possible to maintain the positioning control with the absolute position coordinates after switching the control.

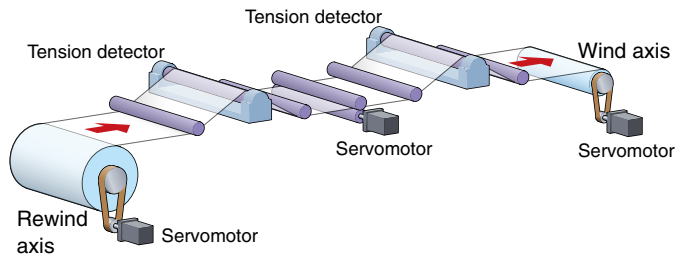

#### Synchronous control and cam control

- Synchronous control and cam control can be combined and used in systems requiring synchronous control.

#### Example applications for cam control

When making a detour around workpiece A and transferring from point P1 to point P3, with positioning control the BUSY signal of axis 1 is checked at point P2, and axis 2 starts.

By using cam control, the BUSY signal does not need to be checked at point P2 so the positioning time is shortened.

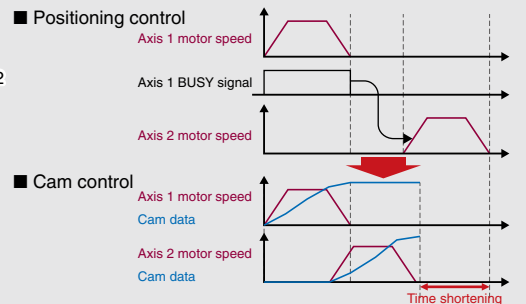
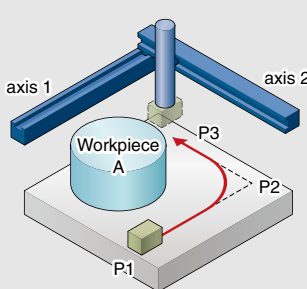

## Making Motion Simple with compactly packed extra functions

### Using synchronous control with a synchronous encoder

- Realize synchronous control and cam control by using input pulses from a synchronous encoder.
- Use an incremental synchronous encoder with the directly built-in interface of LD77MH, or use an absolute synchronous encoder (coming soon) via a servo amplifier. Optional modules are no longer necessary.
- Further improve the synchronization accuracy with the phase compensation function, designed to compensate for synchronous encoder delays.

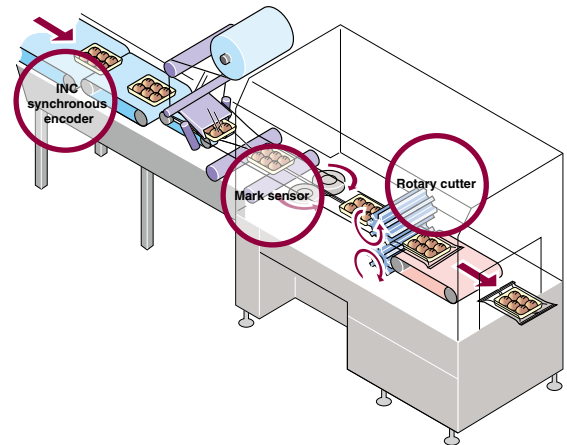

### Standard mark detection function **New**

- The built-in mark detection signal interface allows incorporation in packaging systems etc., without optional modules.

### Automatic cam data generation for rotary cutter

- Easily program and automatically generate difficult cam data for rotary cutters just by specifying the sheet length and synchronization width, etc.

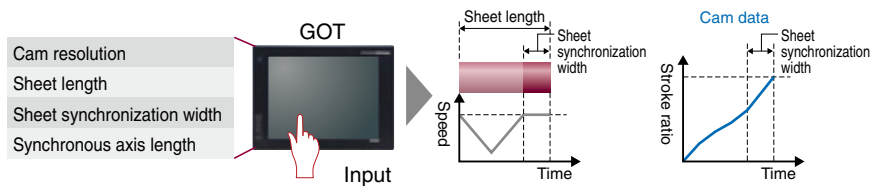

## Making Motion Simple with amplifier-less debugging functions

- Perform programming and debugging on a desktop using just the L Series CPU module, LD77MH and power supply module. This benefits your designing and debugging efficiency.
- Debug sequence programs and positioning data without the servo amplifier and servomotor.

### Amplifier-less operation function

This function carries out the LD77MH positioning control without a servo amplifier connected. Use this to debug the user program for system installation, or to simulate the positioning operation.



## Making Motion Simple in systems requiring high response

- The 50Mbps high-speed optical communication greatly increases the speed of data exchange between the Simple Motion Module and servo amplifier, and reduces the cycle time.
- The degree of freedom in system layout is enhanced for long-distance wiring.
- The adopted optical fiber cable has outstanding noise resistance properties.
- The SSCNET III compatible servo amplifier supports various servomotors, linear servomotors and direct drive motors, and can be used in various applications.



## Simple Settings without Programs

### Simple setting of positioning data

Execute positioning control with the data table method.

- The Data Setting Assistant function simplifies settings.
- Positioning data can be set very simply by using functions such as Automatic Command Speed Calculation, Offline Simulation, and automatic calculation of auxiliary arc, etc.

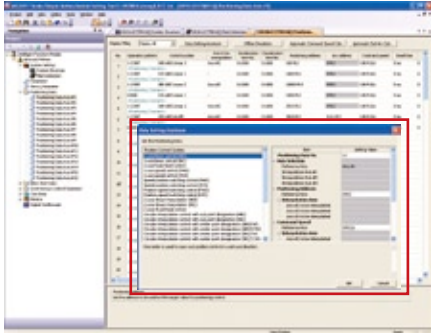

Data Setting Assistant function

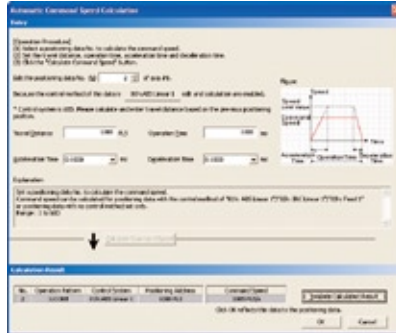

Automatic Command Speed Calculation

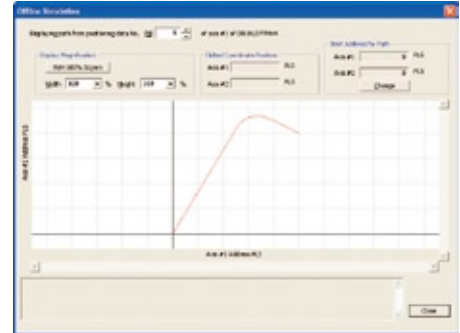

Offline Simulation

### Simple setting of synchronous control data

Using software, realize synchronous control which replaces machine mechanisms, such as the gear, shaft, speed change gear and cam.

- It is possible to realize synchronous control easily with parameter settings. There is no need to create complicated programs.
- Start and stop synchronous control for each axis.  
Use the synchronous control axis and positioning control axis together.
- Convey the travel value of main shaft to the output axis via the clutch.

**New**

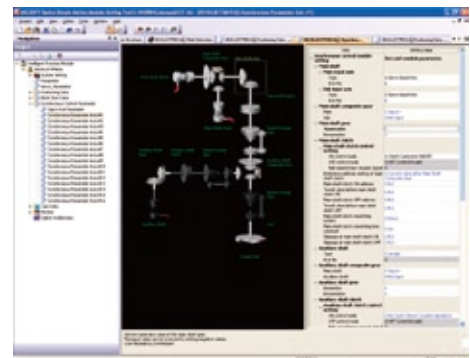

Synchronous Control Parameter Settings

### Simple setting of cam control data

Easily prepare cam data for various patterns.

- Set cams with a high degree of freedom. There's no need to worry about existing concepts of electronic cam control.
- Set the stroke, speed, acceleration and throb while simultaneously checking the profile on a graph.
- Easily check the created cam data by viewing as thumbnail displays of cam data.
- Import and export cam data in CSV format.

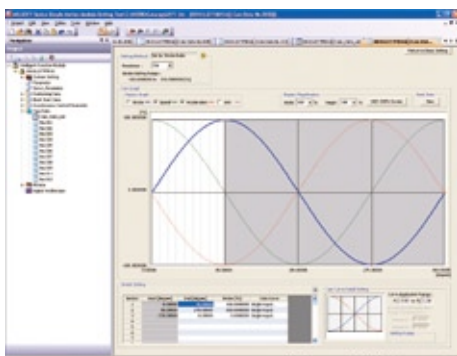

Cam Data

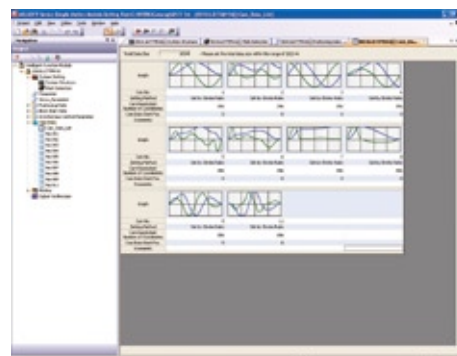

Cam Data List

## Simple parameter settings

- One-point help allows parameters to be set without needing a manual.
- Easily set the applicable servo amplifier on a graphical screen.
- Do away with bothersome electronic gear calculation just by specifying the mechanism configuration (reduction ratio, ball screw pitch, etc.).

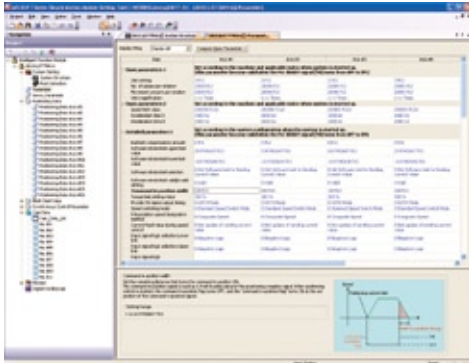

Parameter Settings

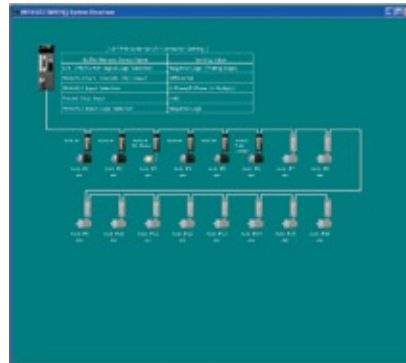

System Structure Setting

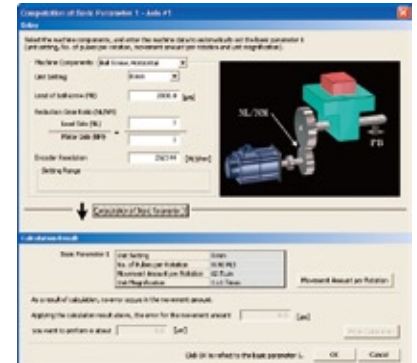

Electronic Gear Settings

## Simple installation

### Digital oscilloscope function

- Collection of data in the Simple Motion Module synchronized with the operation cycle and waveform displays facilitate efficient start up.
- The assistant function explains all work steps.
- Set often-viewed data easily with the purpose-based probe setting.
- Sample 16CH word and 16CH bit data. Of this, 8CH words and 8CH bits can be displayed in real time. **New**

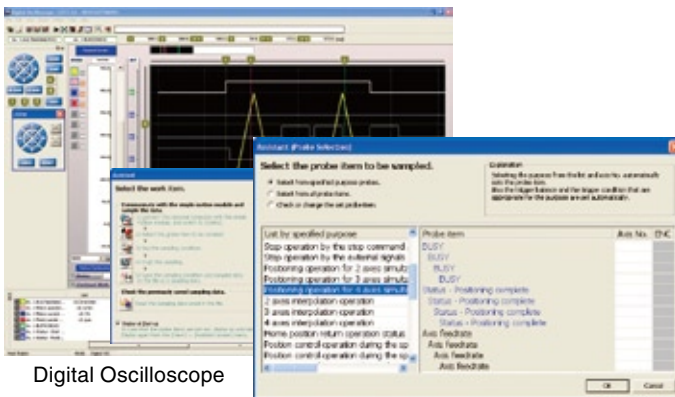

Digital Oscilloscope

### Monitor and test functions

- Easily complete system installation and operation checks with powerful monitor and test functions.
- Select items to be displayed on the monitor from the voluminous information monitor options. **New**
- Use the test function to check basic operations without a sequence program.

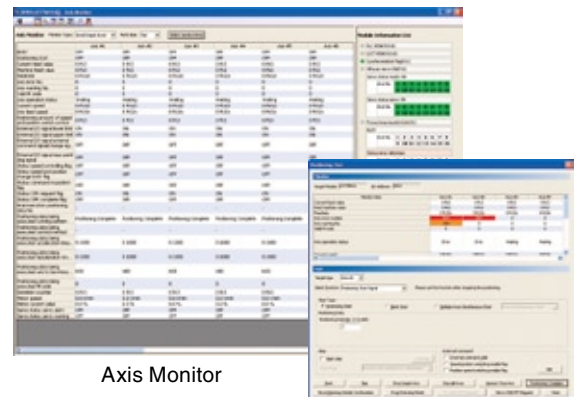

Axis Monitor

Positioning Test

## Simple setting of servo amplifier parameters

Collaboration with the MR Configurator2 increases the servo installation efficiency.

Set and adjust servo amplifier parameters with the MR Configurator2, a treasure trove of Mitsubishi servo know-how.

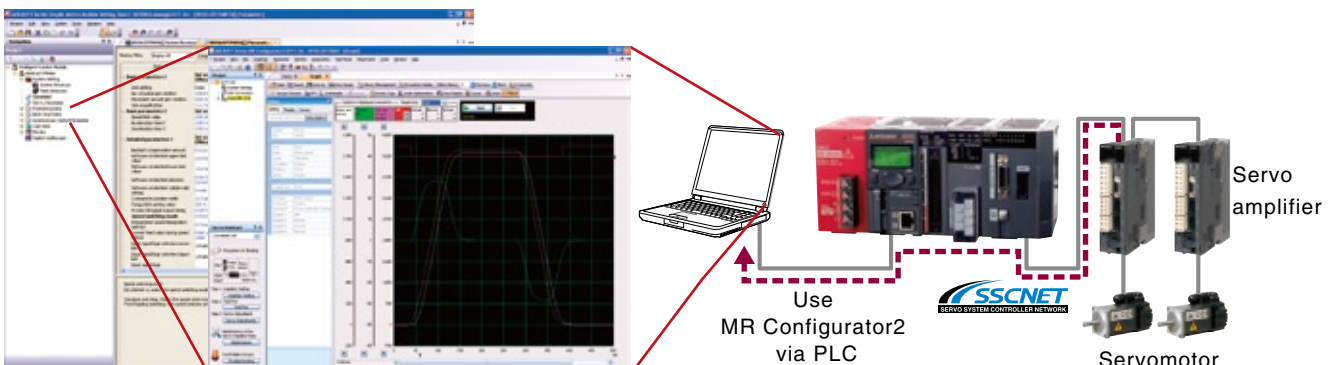

## System Configuration

Structure an integral system consisting of the MR-J3 Series servo amplifier and servomotor with the PLC CPU module and SSCNET III integrated.

- LD77MH4 can control up to 4 axes and the LD77MH16 can control up to 16 axes.

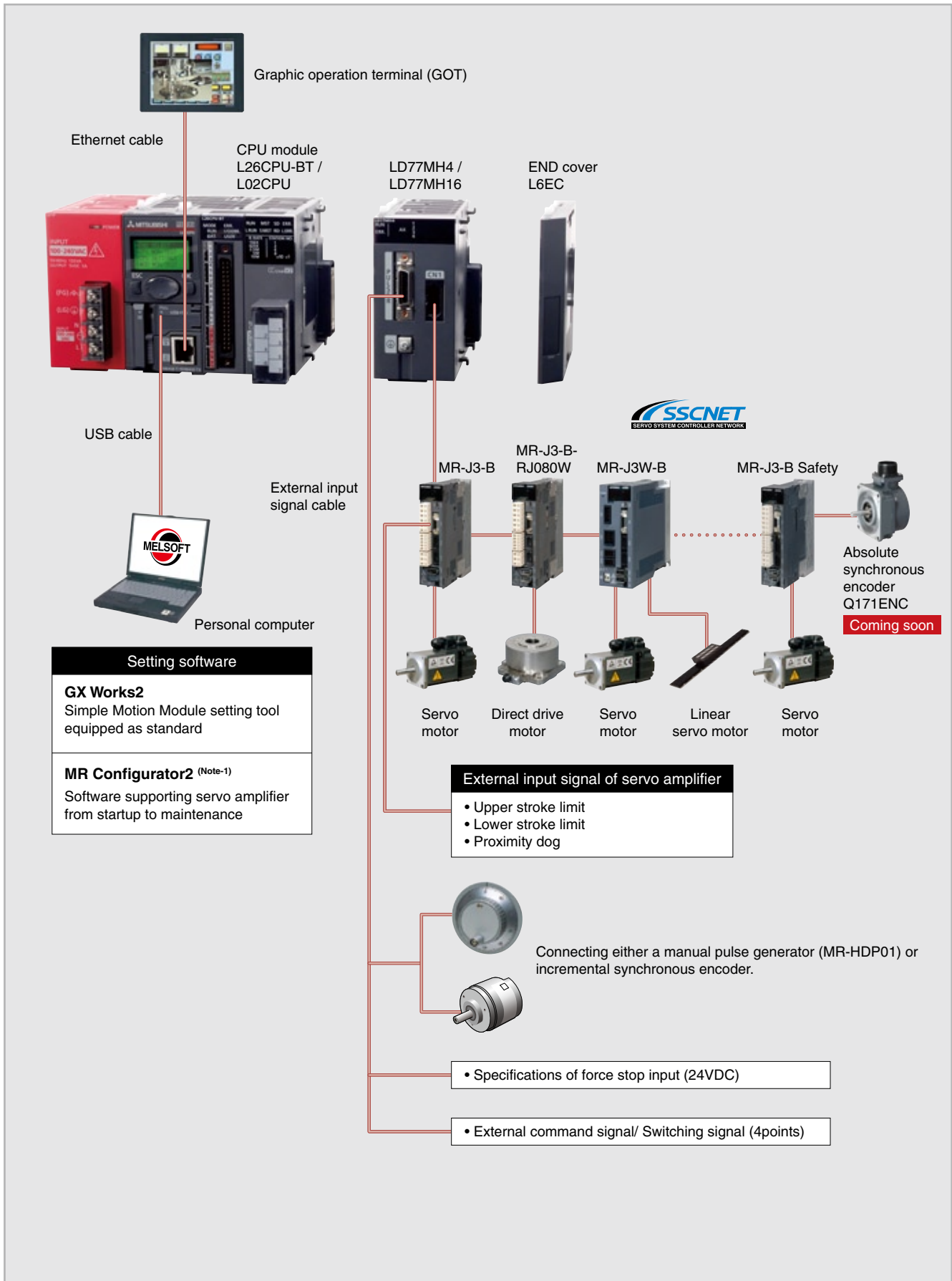

## Module

Item		LD77MH16	LD77MH4	
Servo amplifier connection system		SSCNET III -compatible (50Mbps)		
Transmission Distance		50m(164.04ft)		
PERIPHERAL I/F		Via CPU module (USB, RS-232, Ethernet)		
Interface with external devices	External command signal/ Switching signal	Number of input points	4 points	
		Input method	Positive common/Negative common shared (Photocoupler)	
		Rated input voltage/Rated input current	24VDC/Approx. 5mA	
		Operating voltage range	21.6 to 26.4VDC (24VDC ±10%, ripple ratio 5% or less)	
		ON voltage/current	17.5VDC or more/3.5mA or more	
		OFF voltage/current	5VDC or less/0.9mA or less	
		Input resistance	Approx 5.6kΩ	
		Response time	1ms or less	
		Recommended wire size	AWG24 (0.2mm <sup>2</sup> )	
	Specifications of force stop input signal	Number of input points	1point	
		Input method	Positive common/Negative common shared (Photocoupler)	
		Rated input voltage/Rated input current	24VDC/Approx. 2.4mA	
		Operating voltage range	20.4 to 26.4VDC (24VDC+10%/-15%, ripple ratio 5% or less)	
		ON voltage/current	17.5VDC or more/2.0mA or more	
		OFF voltage/current	1.8VDC or less/0.18mA or less	
		Input resistance	Approx 10kΩ	
		Response time	1ms or less	
		Recommended wire size	AWG24(0.2mm <sup>2</sup> )	
Manual pulse generator/ Incremental synchronous encoder signal	signal input form	Phase A/Phase B(magnification by 4/magnification by 1), PLS/SIGN		
		Input frequency	1Mpps(After magnification by 4, up to 4Mpps)	
	Differential-output type	High-voltage	2.0 to 5.25VDC	
		Low-voltage	0 to 0.8VDC	
	Voltage-output/ High-voltage 3.0 to 5.25VDC Open-collector type (5VDC)	Differential-voltage	±0.2V	
		Cable length	30m(98.43ft)	
		Input frequency	200kpps(After magnification by 4, up to 800kpps)	
			High-voltage	3.0 to 5.25VDC
		Low-voltage	0 to 1.0VDC	
		Cable length	10m(32.81ft)	
Number of I/O occupying points		32 points(I/O allocation: Intelligent, 32 points)		
Maximum number of modules specification		Counts as 2 modules		
Internal current consumption(5VDC)[A]		0.70	0.55	
Mass [kg]		0.22		
Exterior dimensions [mm(inch)]		90.0(3.54)(H)×45.0(1.77)(W)×95(3.74)(D)		

## External Dimension Diagram

LD77MH16

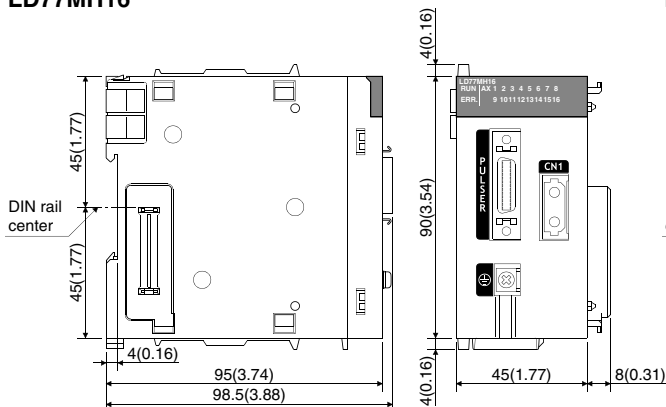

LD77MH4

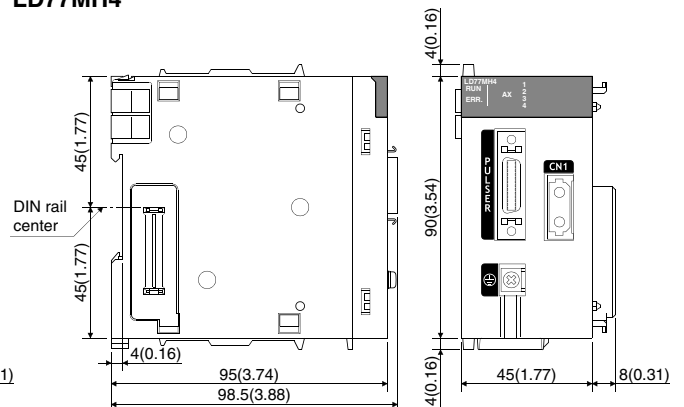

UNIT: mm(inch)

## Motion control

Item		LD77MH16	LD77MH4	
Number of control axes		16axes	4axes	
Operation cycle		0.88ms/1.77ms <sup>(Note-1)</sup>	0.88ms	
Interpolation function		Linear interpolation(Up to 4 axes),Circular interpolation(2 axes)		
Control system		PTP (Point To Point) control, path control (both linear and arc can be set), speed control, torque control, speed-position switching control, position-speed switching control		
Acceleration/deceleration process		Trapezoidal acceleration/deceleration, S-pattern acceleration/deceleration		
Compensation function		Backlash compensation, Electronic gear, Near pass function		
Synchronous control		External encoder, Cam, Phase Compensation, Cam generated automatically		
Control unit		mm, inch, degree, PLS		
Positioning data		600 data (positioning data No. 1 to 600)/ axis (Can be set with GX Works2 or PLC program.)		
Backup		Parameters, positioning data, and block start data can be saved on flash ROM (battery-less backup)		
OPR control	Machine OPR control		Near-point dog method, Count method 1), Count method 2), Data set method, scale origin signal detection method	
	Fast OPR control		Provided	
	Sub functions		OPR retry, OP shift	
Position control	Position control	Linear control	1-axis linear control, 2-axis linear interpolation control, 3-axis linear interpolation control, 4-axis linear interpolation control (Composite speed, Reference axis speed)	
		Fixed-feed control	1-axis fixed-feed control, 2-axis fixed-feed control, 3-axis fixed-feed control, 4-axis fixed-feed control	
		2-axis circular interpolation control	sub point designation, center point designation	
	Speed control		1-axis speed control, 2-axis speed control, 3-axis speed control, 4-axis speed control	
	Speed-position switching control		INC mode, ABS mode	
	Position-speed switching control		INC mode	
	Other control	Current value changing		Changing to a new current value using the positioning data , Changing to a new current value using the start No.
		NOP instruction		Provided
JUMP instruction		Unconditional JUMP, Conditional JUMP		
LOOP,LEND		Provided		
High-level positioning control		Block start, Condition start, Wait start, Simultaneous start, Repeated start		
Manual control	JOG operation		Provided	
	Inching operation		Provided	
	Manual pulse generator operation		Possible to connect 1 module (Incremental) Unit magnification (1 to 10000times)	
Expansion control	Speed-torque control		Speed control without positioning loops, Torque control without positioning loops	
Absolute position system		Made compatible by setting battery to servo amplifier		
Synchronous encoder interface		Up to 4 channel (internal interface , servo amplifier, via the PLC CPU interface )		
Functions that limit control	Internal interface		1channel (Incremental)	
	Via servo amplifier		Support coming soon	
	Speed limit function		Speed limit value, JOG speed limit value	
	Torque limit function		Torque limit value_same setting, torque limit value_individual setting	
	Forced stop function		valid/invalid setting	
	Software stroke limit function		Movable range check with current feed value, movable range check with machine feed value	
Functions that change control details	Hardware stroke limit function		Provided	
	Speed change function		Provided	
	Override function		Provided	
	Acceleration/deceleration time change function		Provided	
	Torque change function		Provided	
Other functions	Target position change function		Target position address and target position speed are changeable	
	M code output function		Provided	
	Step function		Deceleration unit step, Data No. unit step	
	Skip function		Via sequence CPU, Via external command signal	
Mark detection function	Teaching function		Provided	
			Mark detection mode (Continuous Detection mode, Specified Number of Detections mode, Ring Buffer mode)	
	mark detection signal		4points	
mark detection setting	16	4		
Optional data monitor function		4points/axis		
Master-slave operation function		Provided		
Amplifier-less operation function		Provided		
Digital oscilloscope function		bit data :16channels, word data: 16channels <sup>(Note-2)</sup>	bit data :8channels, word data: 4channels	

Note-1 : Default value is 1.77 ms. If necessary, check the operation time and change to 0.88 ms.

Note-2 : 8CH word data and 8CH bit data can be displayed in real time.

## Synchronous control

Item		LD77MH16	LD77MH4
Input axis	Servo input axis	16axes/module	4axes/module
	Synchronous encoder axis	4axes/module	1axis/module
Composite main shaft gear		1/output axis	
Main shaft input axis		1/output axis	
Main shaft sub input axis		1/output axis	
Main shaft gear		1/output axis	
Main shaft clutch		1/output axis	
Auxiliary shaft		1/output axis	
Auxiliary shaft gear		1/output axis	
Auxiliary shaft clutch		1/output axis	
Auxiliary shaft composite gear		1/output axis	
Speed change gear		1/output axis	
Output axis		16axes/module	4axes/module

## Cam

Item		LD77MH16	LD77MH4
Memory capacity	Storage area for cam data	256k bytes	
	Working area for cam data	1024k bytes	
Number of registration		Max. 256 program items (according to memory capacity, cam resolution and number of coordinates)	
Comment		Max. 32 characters (half-byte) for each cam data	
Cam data	Stroke ratio data type	Cam resolution	256,512,1024,2048,4096,8192,16384,32768
		Stroke ratio	-214.7483648 to 214.7483647 [%]
	Coordinate data type	Coordinate number	2 to 16384
		Coordinate data	Output value: -2147483648 to 2147483647
Cam generated automatically		Cam generated automatically for rotary cutter	

## Equipment

Model	Description	Standards
MELSEC-L series Simple Motion Module	LD77MH4 Up to 4 axes control	CE,UL
	LD77MH16 Up to 16 axes control	CE,UL
connector for external input signal cable	LD77MHIOCON Manual pulse generator/ incremental synchronous encoder interface/ Specifications of force stop input interface/ external command signal/ switching signal interface provided with Simple Motion Module	-
SSCNET III cable <sup>(Note-1)</sup>	MR-J3BUS□M	• LD77MH4 ⇔ MR-J3(W)-B Standard cord for inside a panel: 0.15m(0.49ft.),0.3m(0.98ft.),0.5m(1.64ft.),1m(3.28ft.),3m(9.84ft.)
	MR-J3BUS□M-A	• LD77MH16 ⇔ MR-J3(W)-B Standard cable for outside a panel: 5m(16.40ft.),10m(32.81ft.),20m(65.62ft.)
	MR-J3BUS□M-B <sup>(Note-2)</sup>	• MR-J3(W)-B ⇔ MR-J3(W)-B Long-distance cable: 30m(98.43ft.),40m(131.23ft.),50m(164.04ft.)
Manual pulse generator	MR-HDP01 Pulse resolution: 25 PLS/rev -- 100 PLS/rev after magnification by 4 Allowable speed: 200 r/min in normal rotation Voltage output Allowable load Radial load: 19.6 N Thrust load: 9.8 N	-

Note-1 : shows cable length. (015: 0.15m(0.49ft.), 03: 0.3m(0.98ft.), 05: 0.5m(1.64ft.), 1: 1m(3.28ft.), 2: 2m(6.56ft.), 3: 3m(9.84ft.), 5: 5m(16.40ft.), 10: 10m(32.81ft.), 20: 20m(65.62ft.), 30: 30m(98.43ft.),40: 40m(131.23ft.), 50: 50m(164.04ft.)

Note-2 : Check with Mitsubishi Electric regarding cables less than 30m long.

## MELSOFT-Related Tool

Product	Model	Application version	Description
GX Works2	SW1DNC-GXW2-E	Version 1.48A or later	Setting of LD77MH4 and LD77MH16
MR Configurator2	SW1DNC-MRC2-E	Version 1.01B or later	Setting and adjustment of MR-J3 Series servo amplifier

---

## MEMO

---

A series of horizontal dashed lines for writing.



## Precautions before use

This publication explains the typical features and functions of the products herein and does not provide restrictions and other information related to usage and module combinations. Before using the products, always read the product user manuals. Mitsubishi Electric will not be held liable for damage caused by factors found not to be the cause of Mitsubishi Electric; opportunity loss or lost profits caused by faults in Mitsubishi Electric products; damage, secondary damage, or accident compensation, whether foreseeable or not, caused by special factors; damage to products other than Mitsubishi Electric products; and to other duties.

## For safe use

- To use the products given in this publication properly, always read the relevant manuals before use.
- The products have been manufactured as general-purpose parts for general industries, and have not been designed or manufactured to be incorporated in a device or system used in purposes related to human life.
- Before using the products for special purposes such as nuclear power, electric power, aerospace, medicine or passenger movement vehicles, consult with Mitsubishi.
- The products have been manufactured under strict quality control. However, when installing the products where major accidents or losses could occur if the products fail, install appropriate backup or fail-safe functions in the system.

Country/Region	Sales office	Tel/Fax
USA	Mitsubishi Electric Automation Inc. 500 Corporate Woods Parkway Vernon Hills, IL 60061, USA	Tel : +1-847-478-2100 Fax : +1-847-478-0327
Germany	Mitsubishi Electric Europe B.V. German Branch Gothaer Strasse 8 D-40880 Ratingen, Germany	Tel : +49-2102-486-0 Fax : +49-2102-486-1120
UK	Mitsubishi Electric Europe B.V. UK Branch Travellers Lane, Hatfield, Hertfordshire., AL10 8XB, UK	Tel : +44-1707-276100 Fax : +44-1707-278992
Italy	Mitsubishi Electric Europe B.V. Italy Branch Viale Colleoni 7-20041 Agrate Brianza (Milano), Italy	Tel : +39-039-60531 Fax : +39-039-6053312
Spain	Mitsubishi Electric Europe B.V. Spanish Branch Carretera de Rubi 76-80 E-08190 Sant Cugat del Valles(Barcelona), Spain	Tel : +34-93-565-3131 Fax : +34-93-589-1579
France	Mitsubishi Electric Europe B.V. French Branch 25,Boulevard des Bouvets, F-92741 Nanterre Cedex, France	Tel : +33-1-5568-5568 Fax : +33-1-5568-5757
Czech Republic	Mitsubishi Electric Europe B.V. Czech Branch Avenir Business Park, Radlická 714/113a CZ-158 00 Praha 5	Tel : +420-251-551-470 Fax : +420-251-551-471
Poland	Mitsubishi Electric Europe B.V. Polish Branch ul. Krakowska 50 32-083 Balice, Poland	Tel : +48-12-630-47-00 Fax : +48-12-630-47-01
Russia	Mitsubishi Electric Europe B.V. Moscow Office 52/3, Kosmodamianskaya nab., 115054, Moscow, Russia	Tel : +7-812-633-3497 Fax : +7-812-633-3499
China	Mitsubishi Electric Automaiton (China) Ltd. 17/F Chong Hing Finance Center, No.288 West Nanjing Road, Shanghai 200003 China	Tel : +86-21-2322-3030 Fax : +86-21-2322-3000
Taiwan	Setsuyo Enterprise Co., Ltd. 6F., No.105 Wu-Kung 3rd.Rd, Wu-Ku Hsiang, Taipei Hsine 248, Taiwan	Tel : +886-2-2299-2499 Fax : +886-2-2299-2509
Korea	Mitsubishi Electric Automation Korea Co., Ltd. 1480-6, Gayang-dong, Gangseo-ku Seoul 157-200, Korea	Tel : +82-2-3660-9552 Fax : +82-2-3664-8372
Singapore	Mitsubishi Electric Asia Pte, Ltd. 307 Alexandra Road #05-01/02, Mitsubishi Electric Bulding Singapore 159943	Tel : +65-6470-2480 Fax : +65-6476-7439
Thailand	Mitsubishi Electric Automation (Thailand) Co., Ltd. Bang-Chan Industrial Estate No.111 Soi Serithai 54, T.Kannayao, A.Kannayao, Bangkok 10230 Thailand	Tel : +66-2-517-1326 Fax : +66-2-517-1328
Australia	Mitsubishi Electric Australia Pty.Ltd. 348 Victoria Road, Rydalmere, N.S.W 2116, Australia	Tel : +61-2-9684-7777 Fax : +61-2-9684-7245

## MITSUBISHI ELECTRIC CORPORATION

HEAD OFFICE: TOKYO BUILDING, 2-7-3, MARUNOUCHI, CHIYODA-KU, TOKYO 100-8310, JAPAN  
NAGOYA WORKS: 1-14, YADA-MINAMI 5, HIGASHI-KU, NAGOYA, JAPAN